

ines

Suspension lamp
Lampada a sospensione
Lámpara de suspensión

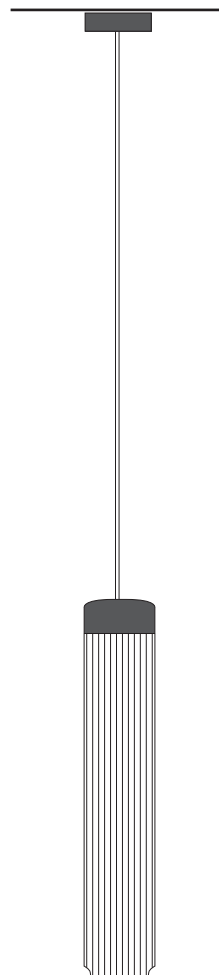
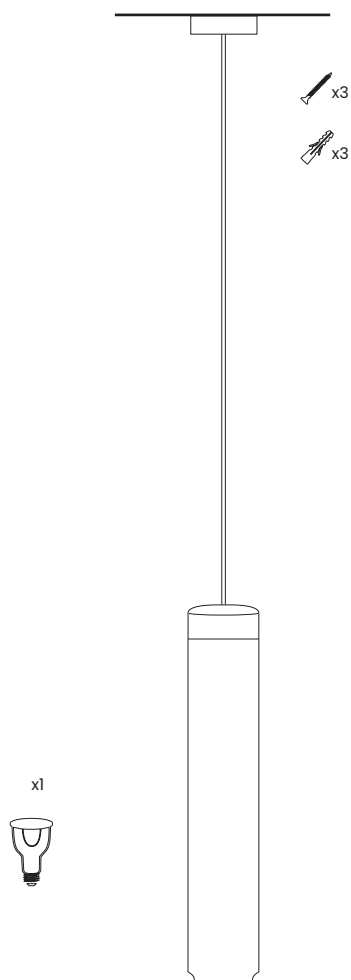

viladecans
www.claraviladecans.com

TECHNICAL CHARACTERISTICS/CARATTERISTICHE TECNICHE/ CARACTERÍSTICAS TÉCNICAS

material/materiale/material: brass and blown glass / ottone e vetro soffiato / latón y cristal soplado
weight / peso / peso (unpacked/ senza imballaggio/ sin embalaje): 3kg
total wire length / longitudine totale del cavo elettrico / longitud total del cable electrico : 5m
portalamparas: GU10
recommended light source / sorgente luminosa consigliata / fuente de luz recomendada: 1 x LED bulb GU10 36° 8.3W 2700K / lampadina LED GU10 36° 8.3W 2700K / Bombilla GU10 36° 8.3W 2700K

IP20  

MAINTENANCE

Clean with a soft dampened cloth. Do not use ammonia products, solvents or abrasives.

MANUTENZIONE

Pulire con un panno morbido inumidito. Non utilizzare prodotti a base di ammoniaca, solventi o abrasivi.

MANTENIMIENTO

Limpiar con un paño suave húmedo con agua. No utilice productos de amoniaco, disolventes o abrasivos.

SAFETY INSTRUCTIONS

Lamp suitable only for indoor use.
Do not place the light source on damp surfaces or those with electric conductivity.
The electric connections must be carried out by specialized personnel.
Always use recommended light source or equivalent.
Do not cover once assembled and connected to the mains.
Before replacing the light source, ensure that it is disconnected from the mains and cold to the touch.
If this electric wire or cord is damaged, it should be replaced exclusively by the manufacturer, its technical service or someone with equivalent qualification in order to avoid any risk.
The manufacturer is not responsible for improper use of the product.

ISTRUZIONI DI SICUREZZA

Lampada adatta solo per interni.
Non posizionare la lampada su superfici bagnate o elettricamente conduttive.
I collegamenti elettrici devono essere eseguiti da personale autorizzato.
Utilizzare sempre la fonte di luce consigliata o equivalente.
Una volta montato e collegato alla rete, non coprirlo.
Prima di sostituire la sorgente luminosa, assicurarsi che la lampada sia scollegata dalla rete e fredda al tatto.
Se il cavo elettrico o il cavo è danneggiato, deve essere sostituito solo dal produttore, dal suo servizio tecnico o da una persona equivalentemente qualificata per evitare qualsiasi rischio.
Il produttore non è responsabile per l'uso improprio del prodotto.

INSTRUCCIONES DE SEGURIDAD

Lámpara apta solo para interiores.
No coloque la lámpara en superficies húmedas ni que presenten conductividad eléctrica. Las conexiones eléctricas deben realizarse por personal autorizado.
Utilice siempre la fuente de luz recomendada o equivalente.
Una vez montada y conectada a la red eléctrica, no la cubra.
Antes de sustituir la fuente de luz, asegúrese de que la lámpara está desconectada de la red y fría al tacto. Si el cable o cordón eléctrico está dañado, debe sustituirse exclusivamente por el fabricante, su servicio técnico o una persona de cualificación equivalente con objetivo de evitar cualquier riesgo.
El fabricante no se hace responsable del uso indebido del producto.

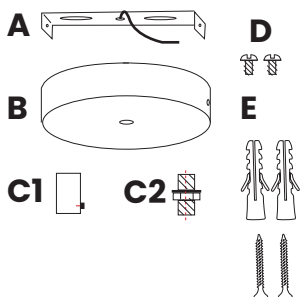
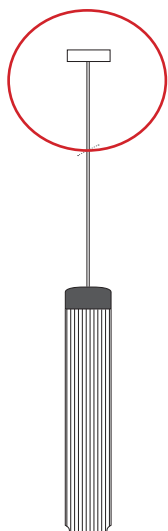

01

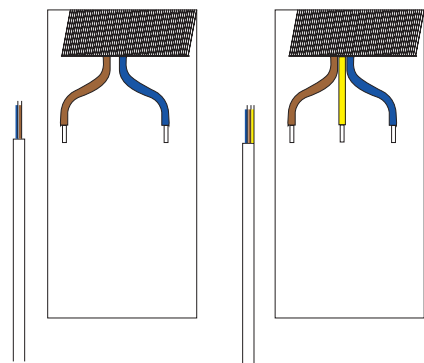

02

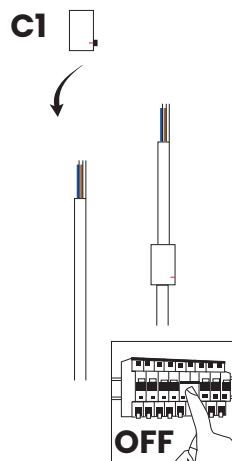

03

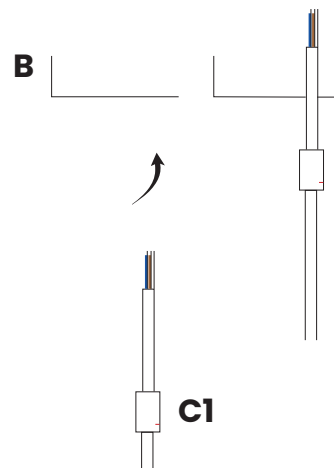

04

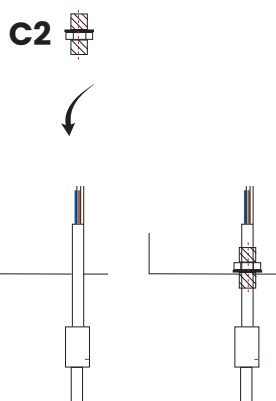

05

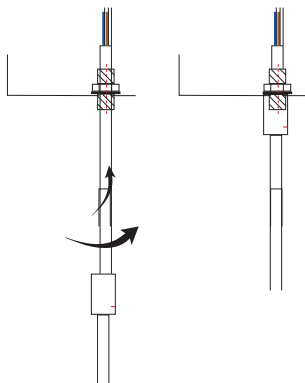

06

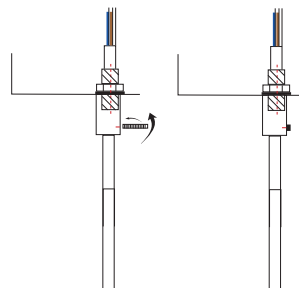

07

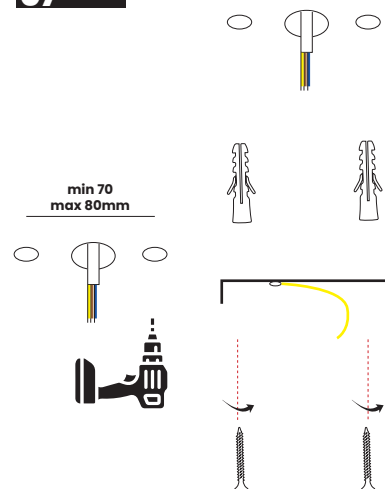

08

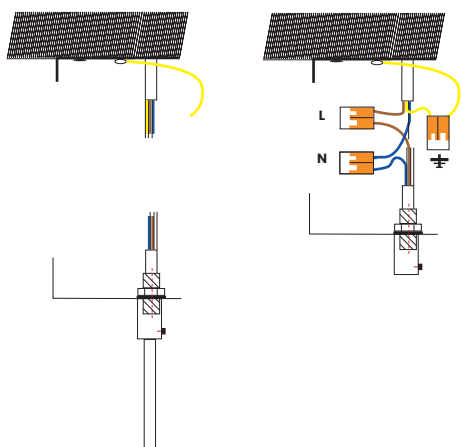

09

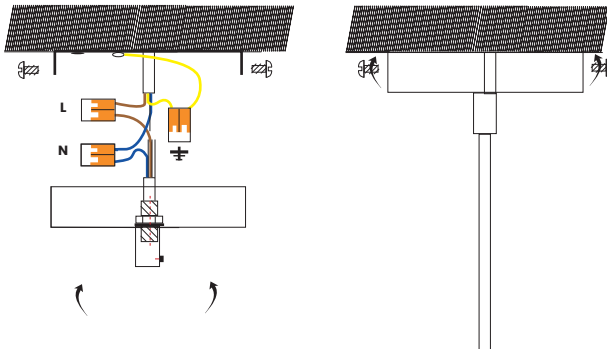

10

